

## Southern Regional Aquaculture Center

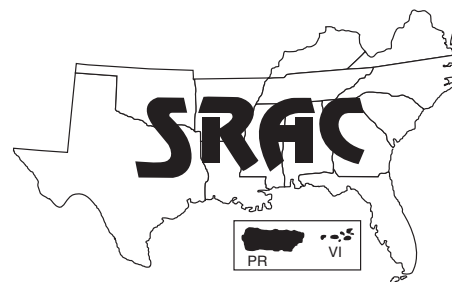

July 2009

# Crawfish Trap Design and Construction

Mark Shirley and C. Greg Lutz<sup>1</sup>

In recent years, annual harvests of 20 to 40 million pounds (9,000 to 18,000 MT) of wild crawfish and 60 to 70 million pounds (27,000 to 32,000 MT) of farmed crawfish have been typical in Louisiana. Virtually all this production is accomplished with baited wire-mesh traps. Baited traps are also the most common method of harvesting crawfish in most other parts of the world. Two basic wire-mesh trap designs have become standards in Louisiana's wild and farmed crawfish industries. Pillow traps (Fig. 1)

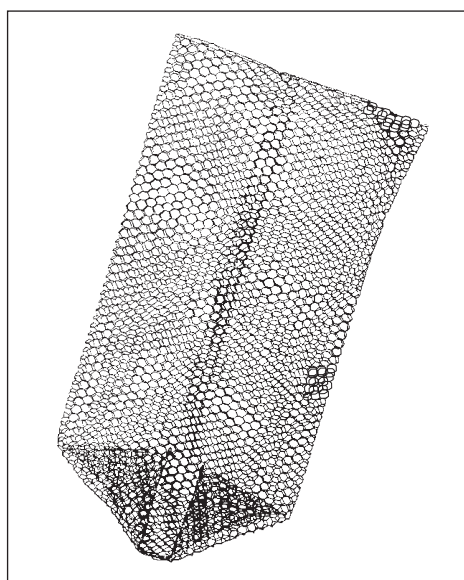
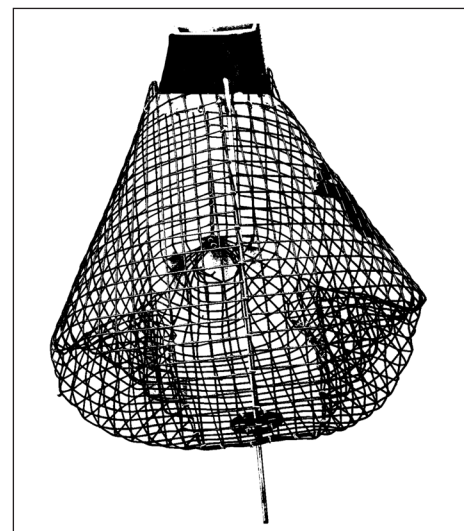

**Figure 1.** Typical pillow trap design made from vinyl-coated,  $\frac{3}{4}$ -inch (1.9-cm) hexagonal-mesh cut 48 inches (122 cm) wide.

have been used for decades in natural swamp habitats such as the Atchafalaya River Basin, where water levels may fluctuate several feet in just a few days. In managed production ponds, where shallow water is maintained, pyramid traps (Fig. 2) have been used since the early 1990s because they are both more effective and easier to handle in shallow water.

The earliest crawfish traps in Louisiana were constructed with hexagonal-mesh, galvanized wire (chicken wire) because it was readily available and relatively inexpensive. But this material was not durable. Traps lost their shape with repeated handling and eventually rusted and broke at stress points. Vinyl-coated chicken wire, introduced in the 1980s, increased the useful life of traps to 3 to 5 years. Recently, vinyl-coated, square-mesh wire has become the preferred material for pyramid traps because it is even more resistant to handling stress and can last for more than 5 years with normal use. Most traps are now made with vinyl-coated, 18-gauge, square-mesh wire, which is lightweight and durable. Aluminum or stainless steel rings are typically used to fasten trap seams.

Mesh size and shape determine the minimum size crawfish retained in a trap. A square-mesh wire will hold a slightly smaller crawfish than a hexagonal-mesh wire of the same dimension. The most common mesh



**Figure 2.** Typical pyramid trap design made from vinyl-coated,  $\frac{3}{4}$ -inch (1.9-cm) square mesh.

sizes are  $\frac{3}{4}$  inch (1.9 cm) and  $\frac{7}{8}$  inch (2.2 cm), because most undersized crawfish can escape through these mesh sizes as traps are raised from the water for dumping. Some Louisiana farmers have tried 1-inch (2.5-cm) mesh traps in an effort to harvest larger crawfish, but where crawfish population densities are high, only a small percentage of the animals ever reach this size.

## Pillow traps

The use of pillow traps goes back more than 50 years, and this design is still used where crawfish are harvested in backwater swamps and

<sup>1</sup>Louisiana State University Agricultural Center

other natural areas. Pillow traps are easily made from vinyl-coated, hexagonal-mesh wire of any width. These traps are shaped like a pillow and have two inverted funnels at the bottom that allow crawfish to enter the trap. The other end is closed off with metal rings, except for one corner that can be opened to extract the crawfish. A clothespin or other simple clamp is typically used to keep the trap closed until the harvester is ready to empty it.

Wire 48 inches wide (122 cm) is a convenient size for pillow trap construction, although some harvesters will make an extended trap so that the top of the trap can reach above the water surface even at depths of more than 1 meter. If water quality is poor, crawfish can suffocate if they are unable to reach the surface once inside the trap. However, if there is even a slight current, traps can normally be deployed completely under water without undue stress on the confined crawfish.

Once baited, pillow traps are usually set in the water by leaning them against a tree stump, stake or other object at about a 45- to 60-degree angle. A cord tying the trap to a branch makes it easy to locate. Crawfish are attracted to the scent of the bait and will crawl around the trap, entering through the funnel in an attempt to reach the bait. If funnels are deep enough and set at the correct angle (avoiding contact with the walls or bottom of the trap), few crawfish will find their way back out of the trap. If funnels are too short or angled downward, many crawfish will easily find their way out of the trap.

Pillow traps are easily stored and transported. The "pillows" can be slightly flattened and stacked one on top of the other. This is especially convenient when large numbers of traps are periodically moved as water levels change in natural environments.

## Pyramid traps

Pyramid traps are the best trap design for use in ponds where water levels are kept between 14 and 24 inches (36 and 46 cm) deep. Craw-

fish farmers no longer use pillow traps in ponds because a stake must be placed at every trap location to lean the pillow against or hang it from. Removing the clothes pin and opening the wire also slows the process of running a line of traps in a pond.

Before pyramid traps, many pond producers had modified the traditional pillow trap design to incorporate a built-in metal rod so traps could be deployed vertically, with a metal flashing-lined opening on one side of the top of the trap. These innovations were incorporated into the pyramid traps used today. The three funnel entrances at the base of a pyramid trap have been shown to catch more crawfish with the same amount of bait than a two-funnel trap, while the flat bottom allows several pounds of crawfish to accumulate in the trap before harvesting.

A key feature of the pyramid trap is the combination collar and handle on the top of the trap, which prevents crawfish from climbing out while making the trap easier to grasp, lift and empty quickly (Fig. 2). This allows pond harvesting to proceed non-stop, with a trap being lifted, dumped and re-baited while the harvest boat is in motion. The newly baited trap is set in place immediately in front of the next trap to be lifted (Fig. 3). The only disadvantage of

pyramid traps is that they are more rigid and bulkier than pillow traps, which makes them harder to transport and store.

Most farmers prefer to have vertical metal rods attached through their pyramid traps to make them more stable so that wind, waves and wildlife cannot overturn them. A  $\frac{5}{8}$ -inch (1.6-cm) rod is usually secured to the plastic collar; it extends down through the center of the trap and protrudes about 6 inches (15 cm) to anchor the trap in the pond bottom (Fig. 2). A cross-bar or disc is typically used to secure the rod to the bottom of the trap as well.

Ideally, the plastic top of the trap should be just above the surface of the water. This allows crawfish to climb to the surface to breathe should dissolved oxygen become a problem. The height of a pyramid trap can be varied by using different widths of wire or cutting the wire to different lengths, but the standard pyramid trap dimensions call for a piece of wire 24 inches (61 cm) wide cut to a length of 52 inches (132 cm). Height can be added by fixing a wire-mesh throat to the top of the pyramid and then attaching the collar at the top of the throat (Fig. 4). Although it adds to the cost of the trap, this modification is commonly used because it makes the trap useable at varying water depths.



**Figure 3.** The handle incorporated into the collar allows a pyramid trap to be lifted, dumped, re-baited and set back in the pond without stopping.

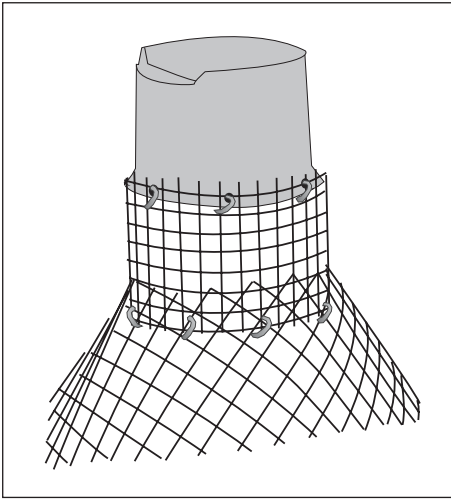

**Figure 4.** Pyramid traps are often made with extensions so they can be used in deeper water. Crawfish should be able to reach the surface to avoid low-oxygen conditions in traps.

## Trap construction

Crawfish traps are fairly easy to make, but constructing a large number of them can take a great deal of time. The tools needed include wire cutters, ring fastener pliers and a wooden spindle or tapered-neck bottle for forming funnels. With hand tools, pillow traps take about 10 minutes to construct, while pyramid traps may take about 20 minutes. Commercial trap makers reduce the time to about 5 minutes by using special devices to pre-cut lengths of wire and automated ring guns to rapidly connect wire seams (Fig. 5).

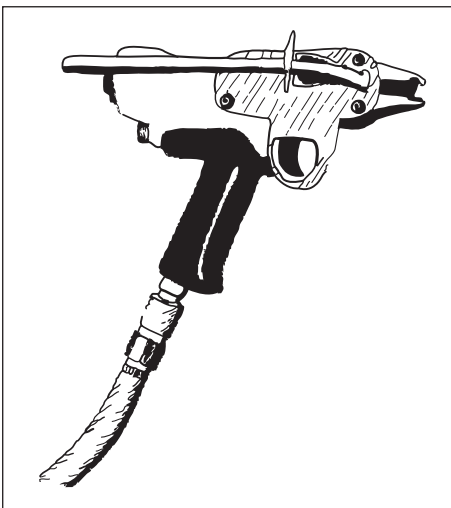

**Figure 5.** Pneumatic ring guns to speed the trap construction process are available from specialty suppliers.

## Pillow trap construction

### Step 1

Cut a piece of vinyl-coated, hexagonal-mesh wire 48 inches (122 cm) wide and 52 inches (132 cm) long.

### Step 2

Connect the cut sides to make an open cylinder by twisting the stubs of the wire together. A modified ice pick (bent at a 90-degree angle) works well for this purpose. Weaving the ends together in this way makes a stiffer seam than simply crimping with rings, and makes the trap stronger and longer lasting. Once the seam is secure, however, it should still be crimped with metal rings to prevent it from eventually opening over time.

### Step 3

Close one end of the trap by fastening the facing edges with metal rings, leaving the last 3 inches (7.6 cm) open at the two corners (Fig. 6). This will be the bottom of the trap.

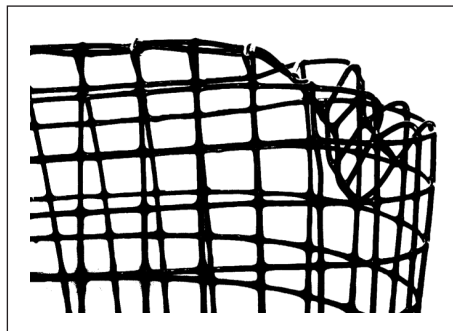

**Figure 6.** The corner of the trap seam is left open, and occasionally bent in slightly, so funnels can be formed.

### Step 4

Close one-half to two-thirds of the top of the trap with metal rings. Use a clothes pin to close the remaining opening.

### Step 5

Invert the two bottom corners over a long-necked bottle or wooden spindle to form funnel entrances. Angle the funnels upward at about a 75- to 80-degree angle (Fig. 7). Trim each entrance hole to be sure it is wide enough for a large crawfish to enter (roughly 2 inches, or 5 cm).

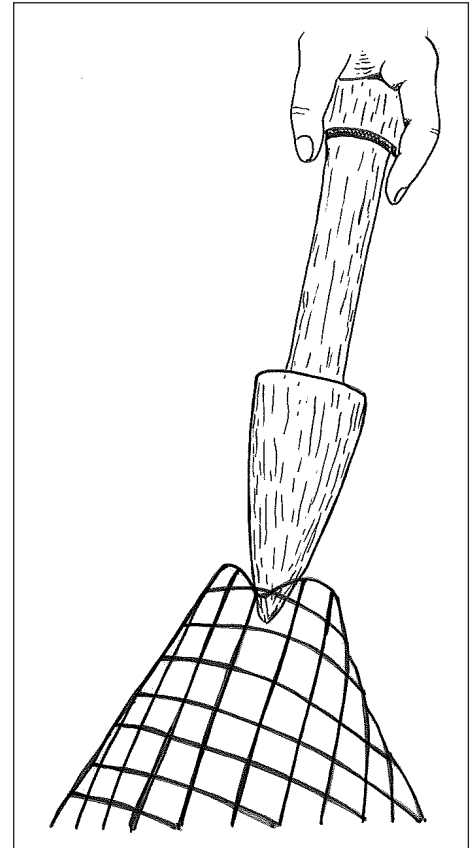

**Figure 7.** A wooden spindle or a long-necked bottle can be used to form funnels.

Several modifications can be made to pillow traps depending on the fishing habitat and the preferences of the harvester. Extended traps can be made by splicing a 24-inch-wide (61-cm) piece of wire to the top of a 48-inch (122-cm) trap. The resulting 60-inch-tall (152-cm) trap can be used in water more than 4 feet deep and still allow crawfish to reach the surface to breathe. This is necessary where floating vegetation is so thick that it covers the entire water surface.

Another variation of the pillow trap is one that sits flat on the bottom and has three funnel entrances. The top corner of the trap that would otherwise be sealed is formed into a third funnel, with the remaining corner clamped closed with a clothes pin as in a typical standing pillow trap. If there is enough current to keep oxygenated water flowing through the trap, this bottom-sitting pillow trap is very effective. A string and/or float can be used to retrieve the trap if needed.

## Pyramid trap construction

As noted above, a pyramid trap usually has a collar at the top to prevent escape and allow it to be lifted more easily. Molded trap collars can be purchased from trap manufacturers. These pieces have a flared bottom edge and a lip in one side of the top edge to make the trap easy to grab. Trap collars also can be made with thin-wall plastic PVC pipe that is 6 inches (15 cm) in diameter and cut into 5-inch (13-cm) pieces. Heat the top edge of the pipe until the plastic is softened, then bend one side over to form a handle. The bottom edge should be heated and then flared outward somewhat to match the angle of the top of the trap.

### Step 1

Cut a piece of vinyl-coated, square-mesh wire that is 52 inches (132 cm) long and 24 inches (61 cm) wide (Fig. 8a).

### Step 2

Fold the wire in half and connect the sides with rings every 1.5 inches (4 cm). Stop 5 inches (13 cm) from one end and fold in the corner to start what will eventually become the third funnel entrance (see below). Add a few more rings, leaving the last 2 inches (5 cm) of the corner open.

### Step 3

Lay the cylinder on its side with the initial seam facing upward. Close one of the open ends with a vertical seam, leaving the corners open to form funnels (Fig. 8b). At this point, the usual practice is to place the collar/handle loosely within the trap before closing it completely (not pictured in photos). Close the open end of the trap with a perpendicular seam. Note: This seam should be horizontal, while the seam on the opposite side remains vertical (Fig. 8c). Leave one corner open for a third funnel. The other corner will be trimmed to serve as the throat of the trap.

### Step 4

Use a long-necked bottle or wooden spindle to form the three funnel entrances of the trap. In one continuous motion, push the bottle into an open

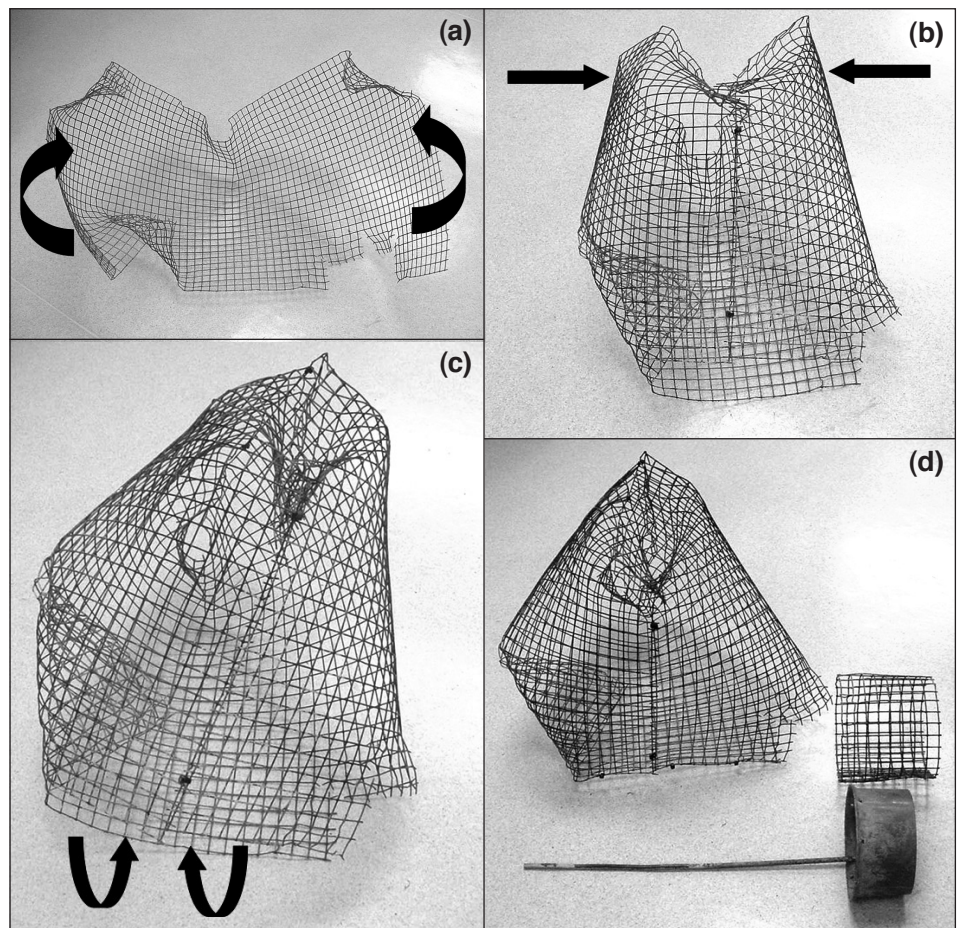

**Figures 8a-d.** The typical process of forming a pyramid trap from a length of square-wire mesh. For illustrative purposes, the wire has been pre-bent to show where funnels will be formed and pre-cut where the collar will be attached to the throat.

corner and extend the funnel about 6 inches (15 cm) into the trap. Funnels should be angled upward at approximately 45 to 50 degrees. The holes should be large enough for a large crawfish to enter. Trim if needed.

### Step 5

Gently flex and bend the wire so that the three corners with funnels lie flat on the bottom (Fig. 8d). A slight crease can be bent into the wire along the bottom edge of the pyramid. If left with a rounded bottom, the trap will easily tip over. The top of the pyramid can now be cut to fit the plastic collar. The hole should be cut slightly smaller than the diameter of the collar. Cut several squares of mesh to allow the collar to squeeze up into the hole (Fig. 9). Use rings to attach the wire to the outside of the handle every 1 to 2 inches (2.5 to 5 cm) around the trap.

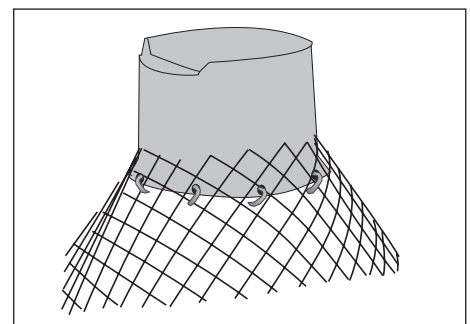
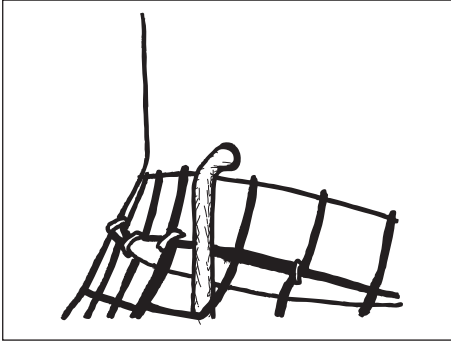

**Figure 9.** The collar should be placed within the trap before the third seam is closed, then pulled into position in the throat and secured with metal rings. Note the lip at the top of the collar to facilitate handling and dumping.

### Step 6 (Optional)

For stability, attach a rod that is 25 inches (64 cm) long and  $\frac{5}{8}$  inch (1.6 cm) in diameter to the plastic handle using several rings through the wire and the plastic top. A  $\frac{3}{4}$ -inch (1.9-

cm), 90-degree bend on the top end of the rod should be positioned into a hole drilled into the plastic handle (Fig. 10). Use a plastic washer to hold the rod in position where it protrudes through the bottom of the trap. Discs made especially for this purpose are available from commercial



**Figure 10.** If a vertical rod is desired, it can be bent and secured through a hole in the trap collar.

trap producers. Use rings to fasten the washer to the bottom. The rod should protrude about 6 inches (15 cm) below the trap (Fig. 11).

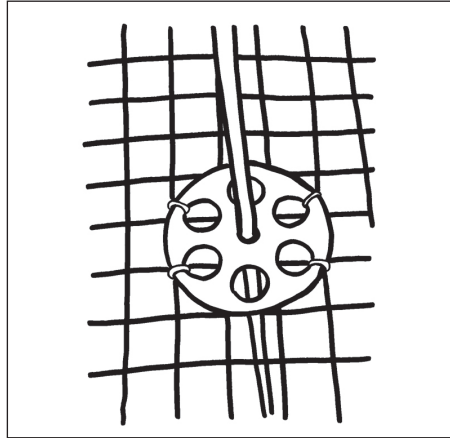

**Figure 11.** Vertical rods should be secured to the trap bottom with plastic discs, which can be fabricated on site or purchased from commercial trap manufacturers.

A slightly smaller pyramid trap can be made by cutting the wire only 48 inches (122 cm) long and following the same steps described above. However, cutting the wire more than 52 inches (132 cm) long will make a trap more cumbersome to handle.

### Specialty traps

Small-mesh traps can be used to catch smaller crawfish for fish bait or as a means of monitoring crawfish populations. Follow the steps described above. Another option is to use purchased minnow traps made with small mesh.

SRAC fact sheets are reviewed annually by the Publications, Videos and Computer Software Steering Committee. Fact sheets are revised as new knowledge becomes available. Fact sheets that have not been revised are considered to reflect the current state of knowledge.



The work reported in this publication was supported in part by the Southern Regional Aquaculture Center through Grant No. 2007-38500-18470 from the United States Department of Agriculture, Cooperative State Research, Education, and Extension Service.